



ASTALE
Nature inspiring innovation

TRANSPORT



INDEX

| | |
|----|---------------------------------|
| 04 | PRODUCT |
| 06 | FINISHES |
| 08 | ADVANTAGES |
| 10 | SUSTAINABILITY |
| 12 | TRANSPORT |
| 14 | PACKAGING AND PREPARATION |
| 18 | MATERIAL LOADING |
| 26 | MATERIAL TRANSPORT |
| 29 | UNLOADING |
| 35 | HANDLING ON SITE / IN WAREHOUSE |
| 38 | RECOMMENDED TOOLS |
| 40 | STORAGE |



Ascale's sintered stone surpasses the limitations of traditional materials, making it the ideal choice for any type of cladding or surface. It offers a versatile, lightweight, and large-format design (162 x 324 cm in thicknesses of 12 and 20 mm, 160 x 320 cm / 120 x 280 cm in thickness of 6 mm and 100 x 300 cm in thickness of 3 mm).

Ascale is the result of combining 100% natural mineral elements through pressure and heat, creating a functional and aesthetically exceptional surface that blends the beauty of natural stone with the strength and durability of sintered stone. A balance between nature and performance.

La piedra sinterizada de Ascale supera las limitaciones de los materiales tradicionales, haciéndolo el material ideal para cualquier tipo de revestimiento y superficie. Ofrece un diseño versátil, ligero y de gran formato (162 x 324 cm en espesores de 12 y 20 mm, 160 x 320 cm / 120x280 cm en espesor de 6 mm y 100 x 300 cm en espesor de 3 mm).

Ascale es el resultado de la combinación de elementos minerales 100% naturales mediante presión y temperatura, logrando una superficie funcional y estéticamente excepcional que combina la estética de la piedra natural con la resistencia y durabilidad de la piedra sinterizada. Un equilibrio entre la naturaleza y el rendimiento.

La pierre frittée Ascale repousse les limites inhérentes aux matériaux habituels, se révélant un choix idéal pour tout type de revêtement ou de surface. Ascale offre un design polyvalent, léger et grand format (162 x 324 cm en épaisseurs de 12 et 20 mm, 160 x 320 cm / 120 x 280 cm en épaisseur de 6 mm et 100 x 300 cm en épaisseur de 3 mm).

Ascale est le résultat de la combinaison d'éléments minéraux 100 % naturels, soumis à la pression et à la chaleur, pour créer une surface fonctionnelle et esthétiquement exceptionnelle, alliant la beauté de la pierre naturelle à la résistance et à la durabilité de la pierre frittée.

Die gesinterte Steinplatte von Ascale überwindet die Grenzen traditioneller Materialien und ist damit das ideale Material für jede Art von Verkleidung und Oberfläche. Sie bietet ein vielseitiges, leichtes Design im Großformat (162 x 324 cm in 12 und 20 mm Stärke, 160 x 320 cm / 120 x 280 cm in 6 mm Stärke und 100 x 300 cm in 3 mm Stärke).

Ascale ist das Ergebnis der Verbindung von 100 % natürlichen Mineralien, die unter Druck und Hitze zu einer funktionalen und ästhetisch außergewöhnlichen Oberfläche verschmolzen werden. So entsteht ein Material, das die Optik von Naturstein mit der Widerstandsfähigkeit und Langlebigkeit von gesintertem Stein vereint.

Thickness

3 mm / 6 mm / 12 mm / 20 mm

Finish

Polished • Matt • Feel • Velvet | *Vein-touch* & 

Size

100 x 300 cm / 120 x 280 cm / 160 x 320 cm / 162 x 324 cm

Light awaken textures



Advantages

-  ● LIGHTNESS / LIGEREZA / LÉGÈRETÉ / LEICHTIGKEIT
- EU** ● MADE IN EU / FABRICADO EN / FABRIQUÉ EN / HERGESTELLT IN
-  ● WATERPROOF / IMPERMEABLE / IMPERMÉABILITÉ / WASSERDICHT
-  ● CUT RESISTANCE / RESISTENCIA AL CORTE / RÉSISTANCE AU CISAILLEMENT / SCHERFESTIGKEIT
-  ● RECYCLED / RECIOLADO / RECYCLAGE/ RECYCLING
-  ● LARGE FORMAT / GRAN FORMATO / GRAND FORMAT / GROSSES FORMAT
-  ● 100% NATURAL / 100% NATURAL / 100% NATUREL / 100% NATÜRLICH
-  ● UV RESISTANCE / RESISTENCIA RAYOS UV / RÉSISTANCE AUX UV / UV-BESTÄNDIGKEIT
-  ● HIGH RESISTANCE / ALTA RESISTENCIA / HAUTE RÉSISTANCE / HOHE WIDERSTANDSFÄHIGKEIT
-  ● HYGIENIC / HIGIÉNICO / HYGIÉNIQUE / HYGIENISCH
-  ● LOW TEMPERATURES RESISTANCE / RESISTENCIA A BAJAS TEMPERATURAS / RÉSISTANCE AUX BASSES TEMPÉRATURES / NIEDRIGE TEMPERATURBESTÄNDIGKEIT
-  ● HIGH TEMPERATURES RESISTANCE / RESISTENCIA A ALTAS TEMPERATURAS / RÉSISTANCE AUX HAUTES TEMPÉRATURES / HOHE TEMPERATURBESTÄNDIGKEIT
-  ● STAIN RESISTANCE / ANTIMANCHAS / ANTI-TACHES / FLECKENBESTÄNDIG

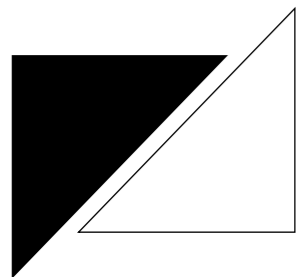

EASY-cut

DREAM **BIGGER**, CUT **SIMPLE**



Ascale has an environmental management system in place to identify and minimize the impact of its operations on air emissions, wastewater, waste, and noise pollution.

Our commitment is backed by ISO 14001 certification, which attests to the effectiveness of our environmental management system in line with the most stringent international standards, with production processes focused on preventing and reducing environmental impact at every stage of our activity.

Ascale also holds a Carbon Footprint certificate, enabling us to measure and control our greenhouse gas emissions — a significant step towards more sustainable and low-carbon production.

Ascale cuenta con un sistema de gestión ambiental para identificar y minimizar el impacto de sus operaciones sobre las emisiones atmosféricas, aguas residuales, residuos y contaminación acústica.

Nuestro compromiso se ve respaldado por la certificación ISO 14001, que acredita la eficacia de nuestro sistema de gestión ambiental conforme a los estándares internacionales más exigentes.

Ascale dispone del certificado de Huella de Carbono, que nos permite medir y controlar nuestras emisiones de gases de efecto invernadero, siendo un gran paso hacia una producción más sostenible y baja en carbono.

Ascale dispose d'un système de gestion environnementale permettant d'identifier et de minimiser l'impact de ses activités sur les émissions atmosphériques, les eaux usées, les déchets et la pollution sonore.

Notre engagement est soutenu par la certification ISO 14001, qui atteste de l'efficacité de notre système de gestion environnementale selon les normes internationales les plus rigoureuses.

Ascale est également titulaire du certificat d'empreinte carbone, qui nous permet de mesurer et de contrôler nos émissions de gaz à effet de serre — une avancée majeure vers une production plus durable et à faible émission de carbone.

Ascale verfügt über ein Umweltmanagementsystem, um die Auswirkungen seiner Tätigkeiten auf Luftemissionen, Abwasser, Abfall und Lärmbelästigung zu ermitteln und zu minimieren.

Unser Engagement wird durch die Zertifizierung nach ISO 14001 bestätigt, die die Wirksamkeit unseres Umweltmanagementsystems gemäß den strengsten internationalen Standards bescheinigt.

Ascale verfügt über das Carbon Footprint-Zertifikat, das es uns ermöglicht, unsere Treibhausgasemissionen zu messen und zu kontrollieren, was ein großer Schritt in Richtung einer nachhaltigeren und kohlenstoffärmeren Produktion ist.

Certificates:



* Consult the official list for certified models / Consultar listado oficial para modelos certificados
 Consulter la liste officielle des modèles certifiés / Offizielle Liste der zertifizierten Modelle konsultieren.

Applying criteria of continuous improvement, we conduct internal waste recovery and implement selective waste collection of materials such as cardboard, plastic or wood.

Ascale is committed to the optimisation of water management, based on the principles of reuse and optimisation in the different processes.

It is also committed to the endless application of energy efficiency criteria in its facilities and activities.

Aplicando criterios de mejora continua, llevamos a cabo una revalorización interna de los residuos y una recogida selectiva de los mismos como cartón, plástico o madera.

Ascale está comprometida con la optimización en la gestión del agua, basada en los principios de reutilización y optimización de esta en los diferentes procesos.

Además, apuesta por la aplicación constante de criterios de eficiencia energética en sus instalaciones y actividades.

Un compromiso que se traduce en la adopción de prácticas ambientales orientadas a la reducción del impacto ambiental.

Selon des critères d'amélioration continue, nous assurons une récupération des déchets et une collecte sélective de matériaux tels que le carton, le plastique ou le bois.

Ascale s'engage à optimiser la gestion de l'eau, en se basant sur les principes de réutilisation et d'optimisation dans les différents processus.

De plus, elle mise sur l'application constante de critères d'efficacité énergétique dans ses installations et activités.

Unter Anwendung von Kriterien der kontinuierlichen Verbesserung führen wir eine interne Wiederverwertung von Abfällen sowie eine getrennte Sammlung von Materialien wie Karton, Kunststoff oder Holz durch.

Ascale verpflichtet sich zur Optimierung des Wassermanagements auf der Grundlage der Prinzipien der Wiederverwendung und Optimierung in den verschiedenen Prozessen.

Darüber hinaus setzt das Unternehmen auf die kontinuierliche Anwendung von Kriterien der Energieeffizienz in seinen Anlagen und Aktivitäten.



05/Transport



A-FRAME

Packaging system designed for the transport of large-format sintered stone, in which the slabs are positioned at an angle on a rigid “A”-shaped structure or vertical metal support.

It is used exclusively for the transport of large formats, such as our 280 and 320 cm slabs.

Advantages

- Maximum protection and stability during the transport of large-format slabs
- Reduces the risk of flexural stress in long-format materials
- Facilitates handling with forklifts



Ensures material stability during handling and transport, minimizing the risk of breakage caused by bending, impact, or vibration.

BUNDLE

Packaging system in which the slabs are grouped in a horizontal position with perimeter protective elements.

It is used for the efficient organization and transport of our large-format sintered stone slabs.

Advantages

- Optimizes space efficiency during transport and storage
- Enables agile handling during loading and unloading
- Ensures load stability during transportation



Efficient packaging format that allows large-format slabs to be grouped and protected, optimizing space without compromising transport safety.

BIG A-FRAME

Heavy-duty, fully metallic packaging structure specifically designed for the transport of large-format sintered stone in 280 and 320 cm size.

Its reinforced design is intended for demanding handling conditions, export operations, and long-distance transportation.

Advantages

- Maximum protection for large-format slabs
- Compatible with crane handling
- Ideal for international transport and industrial logistics



High-resistance system designed to ensure the integrity of sintered stone under demanding logistics conditions and long-distance transport.

Good palletizing practices

- Always respect the maximum number of slabs per package
- Distribute weight evenly
- Ensure proper securing of the slabs to prevent movement
- Use additional protection at critical points (edge protectors, separators, stretch film, etc.)
- Verify the stability of the load before transport

⚠ Risks of poor palletizing

- Packaging overload causing deformation or breakage
- Movement during transport resulting in edge or surface damage
- Difficult handling leading to increased incidents on-site or in storage
- Loss of logistics efficiency

EDGE PROTECTION

Real risks

- Impacts during handling with suction cups
- Vibration during transport
- Contact between slabs inside the packaging
- Impacts during loading and unloading

Technical solutions used

- High-density foam corner protectors: protect corners (the most fragile area)
- "U" or "L" shaped rubber/foam profiles: protect the entire edge perimeter
- Complete separation between slabs: no direct ceramic-to-ceramic contact
- Reinforced multilayer technical cardboard edges: absorb micro-impacts

The edge is the most common structural failure point in large-format slabs; therefore, perimeter protection is mandatory, not optional.

In large-format materials, the edge is the most vulnerable area of the slab and the origin of most incidents during transport and handling.

Although not always explicitly specified, on-site and logistics experience demonstrates that inadequate protection at this critical point can compromise the integrity of the entire slab.

Real Problem

- High edge sensitivity to impacts and micro-impacts
- Risk of chipping or microcracks
- Cumulative damage during transport and handling
- Poorly distributed pressure points generating internal stress

Protection Principles

- Use rigid packaging capable of absorbing impacts
- Ensure continuous and uniform slab support
- Avoid point loads or pressure concentrations
- Minimize movement inside the packaging

Recommended solutions

- Protective corner guards: reinforce the most exposed points and reduce damage to corners and edges
- Separators between slabs: prevent direct contact between panels and reduce friction and micro-impacts
- Technical foam protection: absorbs vibrations during transport and distributes loads evenly
- Appropriate fixing systems: prevent internal displacement and increase overall load stability

⚠ Common Mistakes

- Point or uneven support
- Lack of corner protection
- Excessive pressure caused by overloading
- Slab movement inside the packaging





HOW TO PROPERLY LOAD THE TRUCK

Before starting any operation, it is essential to accurately plan how the material will be distributed and secured inside the vehicle.

First, the exact weight distribution must be defined, ensuring a balanced load arrangement that guarantees truck stability during transport. Based on this, the specific positioning of each unit — whether crates, cavallettos, or maximum-load configurations — is determined according to their characteristics and support requirements

It is also necessary to plan the loading sequence according to the intended delivery route. This allows for more efficient unloading at destination, following the principle that the last item loaded should be the first item unloaded.

In addition, the most suitable internal securing system must be determined, using elements such as straps, blocking systems, or separators to prevent any movement during transit. Likewise, it is essential to correctly identify the anchoring and fixing points inside the vehicle to ensure the load remains completely immobilized.

The objective of this planning process is to guarantee load stability, prevent movement during transport, and optimize operations at the delivery point.

Correct support

- Continuous or evenly distributed contact at the base
- Uniform structural support surface
- Absence of concentrated pressure points
- Support on stable and level surfaces

Incorrect support

- Support on corners or edges
- Point loads concentrated in specific areas
- Direct contact between slabs without protection
- Irregular surfaces or surfaces without vibration absorption capacity

WEIGHT DISTRIBUTION

The basic principle is clear: weight distribution is not adjusted during loading, but calculated and defined in advance. Load distribution follows a fixed technical plan based on stowage tables that determine exactly how each shipment must be organized.

This means that each format has a known unit weight, each package has a pre-calculated total weight, and each vehicle has clearly defined load limits. The combination of these factors results in a loading plan that leaves no room for improvisation, as both transport safety and regulatory compliance depend on it.

In the case of containers, distribution varies depending on the type:

20' Container

Primarily used for more compact or heavier loads. In this case, distribution must be centered to avoid imbalances that could compromise stability. Here, safety takes priority over space optimization.

- Lower capacity, higher load density
- Strict control of the center of gravity
- Limited combination of formats

40' Container

Offers greater flexibility in distribution and allows different formats to be combined, always under technical supervision. The goal is a more efficient use of volume without compromising stability.

- Balanced distribution throughout the container
- Organization by loading modules to improve control

In truck transport, the distribution logic changes slightly, but remains equally strict. Weight must be correctly distributed between the front axle and the rear axles, always respecting the established limits for each one

It is important to understand that staying below the maximum permitted total weight is not enough. Poor distribution can overload a specific axle, directly affecting safety, driving performance, and legal compliance.

Ultimately, weight distribution is not only intended to optimize space, but also to guarantee stable vehicle behavior throughout the entire journey.

SECURING SYSTEMS

The securing system must guarantee full control over the behavior of the material during transport:

- Prevent longitudinal movement (braking and acceleration)
- Prevent lateral movement (curves, direction changes, vibrations)
- Eliminate internal micro-movements between slabs

If movement exists, even if imperceptible, there is a risk of structural damage.

COMPONENTS OF THE SECURING SYSTEM

Lashing straps

Lashing straps are the main fixing element in the transport of large-format material and play an essential role in the overall stability of the load. Their correct selection and use not only guarantee load immobilization, but also prevent unwanted stresses that could compromise the integrity of the material.

For this type of application, high-strength straps should be used, preferably made from technical textile materials or polyester, capable of withstanding the loads generated during transport without loss of performance. These straps must always be anchored to the structural points of the vehicle, ensuring a firm and reliable connection between the load and the transport system.

One particularly critical aspect is the correct tension adjustment. The strap must be applied with controlled pressure, sufficient to prevent any displacement while avoiding both slackness and excessive tension. An improperly tensioned strap loses its safety function, while excessive tension can create counterproductive effects.

The main function of the straps is to secure the assembly formed by the frame and the slabs to the vehicle, preventing movement both along the longitudinal axis (during braking or acceleration) and along the vertical axis (caused by terrain irregularities or vibrations).



Lashing straps must always be used together with corner protectors to prevent direct contact with the slabs or packaging.

Anti-Slip Systems

Anti-slip systems are an essential element in controlling load stability, especially against forces generated by continuous vehicle vibration and speed changes during transport.

These systems are based on the use of high-friction materials, such as technical rubber or anti-slip pads, strategically placed on contact surfaces. Their positioning is critical to their effectiveness and they should mainly be installed:

- Between the load and the vehicle floor
- Between the load and support structures (frames, cavallettos, etc.)

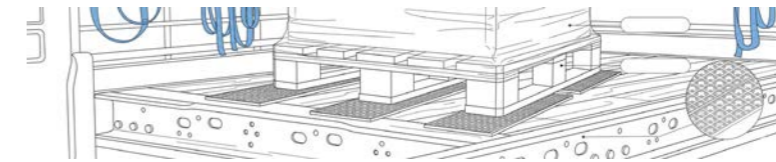

The main function of these elements is to increase surface grip, preventing progressive sliding that, although initially imperceptible, can generate cumulative movement and eventually cause material damage.

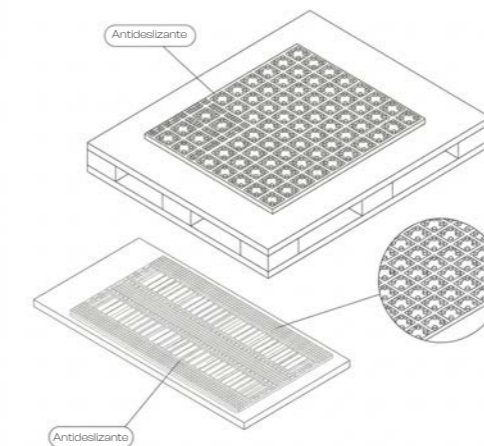

In addition, anti-slip systems help reduce the effect of inertia during braking and acceleration, assisting in keeping the load in its original position without relying exclusively on lashing straps. In this way, the workload on the main securing systems is reduced and the overall stability of the load is improved.

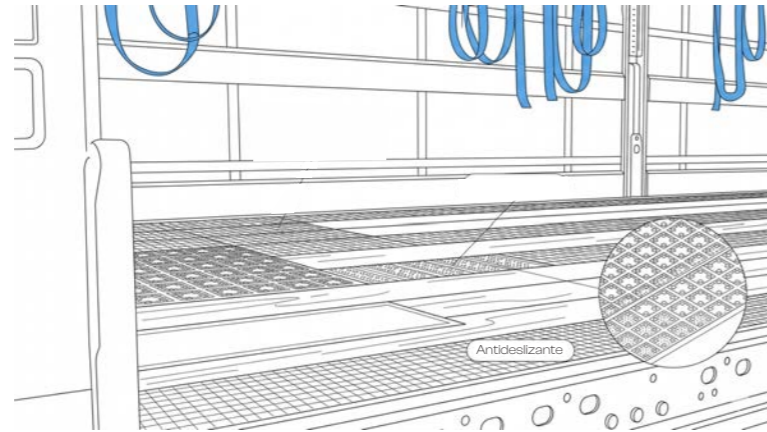

From an operational perspective, their use transforms a potentially slippery surface into a stable base, significantly reducing the risk of displacement caused by constant vibrations, uneven terrain, or vehicle maneuvers.

Ultimately, anti-slip systems act not only as a complement, but as a key reinforcement within the securing system, contributing to safer and more controlled transport of large-format material.

Separation Between Loads

Separation between loads is a fundamental element in preserving material integrity during transport, especially for large-format products where any uncontrolled contact can result in visible or structural damage.

This system is based on the incorporation of physical separators between packages, frames, or slabs, whose function is to prevent direct contact and control the interaction between different load elements. To achieve this, materials specifically designed to absorb impacts and reduce force transmission are used, such as:

- Technical foam
- Multilayer technical cardboard
- Structural plastic profiles

These materials must be strategically positioned at potential contact points, ensuring effective and continuous separation between different units.

The main function of this system is to prevent direct contact between slabs, eliminating the risk of scratches, chipping, or edge damage. In addition, separators act as cushioning elements capable of absorbing micro-impacts generated during transport, particularly those caused by vibrations, uneven terrain, or vehicle movement.

Another key aspect is their ability to interrupt vibration transmission between loads. Without proper separation, vibrations can propagate from one slab to another, amplifying their effect and increasing the risk of progressive material deterioration.

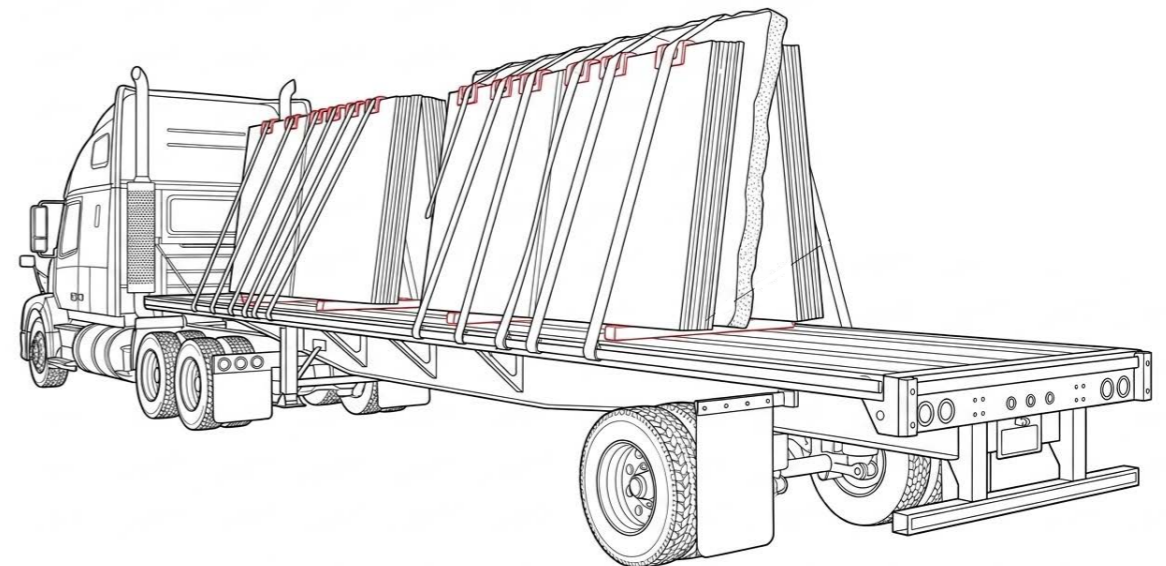

CORRECT VS INCORRECT LOAD STABILITY

Correct practices

• Balanced Load

- Weight distribution must be homogeneous across the entire pallet or support surface.
- Avoid concentrating weight in a single point.
- Guarantees stability during transport, handling, and storage.
- Reduces the risk of tipping or load displacement.

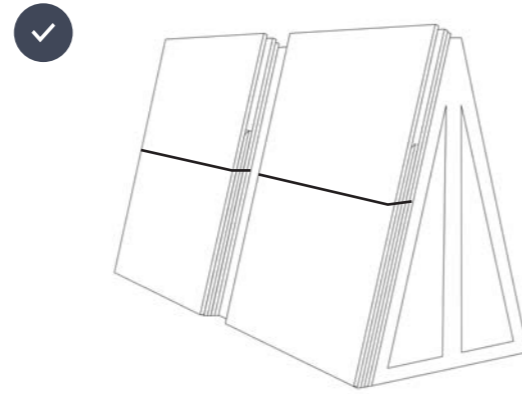

• Aligned Slabs

- Materials must be placed perfectly aligned with each other and with the pallet base.
- A consistent vertical structure must be maintained (without protruding elements).
- Facilitates strapping, stacking, and handling with forklifts or suction cups.
- Improves the overall resistance of the load during vibrations or impacts.

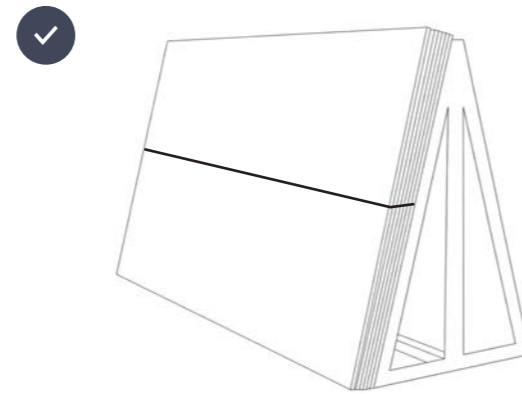

• No Gaps

- Packages must remain compact and secure, without empty spaces between slabs or layers.
- Filling or separation elements should be used when necessary.
- Prevents internal movement that may cause breakage or micro-impacts.
- Increases the structural stability of the load during transport.

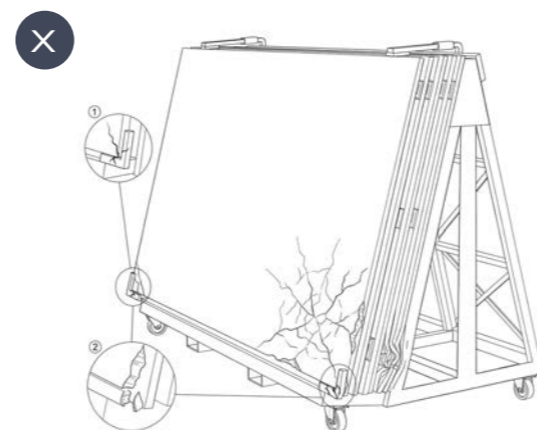
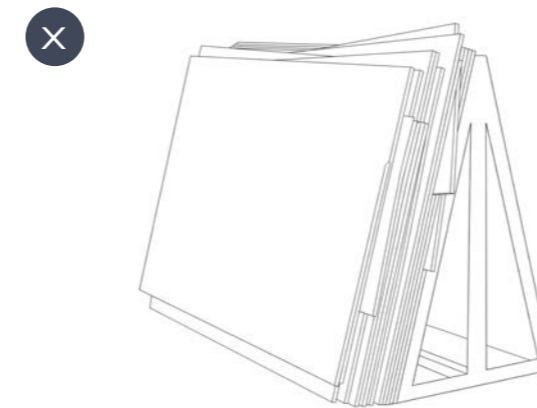
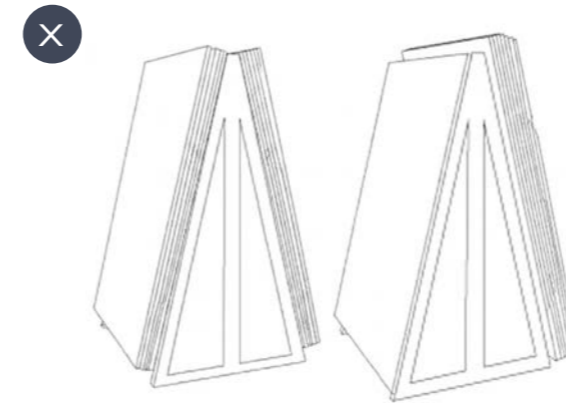
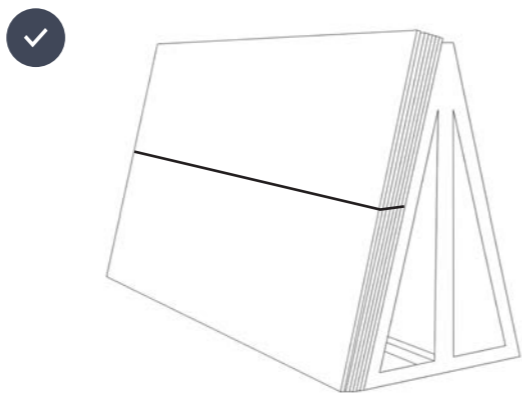

Incorrect practices

• Loose Load

- Presence of internal movement within the packaging or between slabs.
- Lack of proper securing or compaction.
- Causes displacement during braking, turning, or vibrations.
- Increases the risk of breakage and pallet instability.

• Unbalanced Weight

- Irregular weight distribution on the pallet or load structure.
- Excessive concentration in one area (side, top, or bottom).
- Can cause progressive tilting or collapse of the stack.
- Makes safe handling with mechanical equipment more difficult.

• Pressure on Edges

- Direct or excessive support on slab edges.
- Creates stress concentration points that may cause cracks or chipping.
- Especially critical in ceramic or large-format materials.
- Must be avoided through the use of separators, flat bases, or technical protection systems.



RECOMMENDED CONDITIONS

Vehicle environmental stability

- Internal temperature control:
 - Sudden temperature changes inside the vehicle or container during transport must be avoided.
 - Thermal variations can cause expansion or contraction in packaging and auxiliary materials.
 - This is especially important on long-distance routes or when passing through different climate zones.
- Condensation prevention:
 - Moisture condensation inside the vehicle should be minimized.
 - Condensation may occur due to temperature differences between the load, the air, and the metal surfaces of the container.
 - It is recommended to maintain adequate ventilation or use humidity control systems whenever possible.
- Dry Environment During Transport
 - Material must be transported under low relative humidity conditions.
 - Although the product itself may not be directly affected, humidity can compromise packaging system components.
 - Exposure to humid environments should be avoided, especially during long-term transport or intermediate storage.

Important

Humidity does not usually damage the ceramic slab or the main material directly. However, it can critically affect:

- Cardboard packaging
- Straps and securing systems
- Separators and cushioning elements
- Overall palletized load stability

The degradation of these elements can result in loss of load stability, internal displacement, and increased risk of breakage during transport or handling.

Load Stability During Transit

- Completely secured load (No Gaps)
 - The load must remain fully immobilized within the transport system..
 - There must be no empty spaces between the pallet, packaging, and containment elements..
 - Any gap, even minimal, can become amplified during transport due to vibrations and inertia changes.
 - It is recommended to verify the compactness of the load before closing the vehicle.
- Securing Maintained Throughout the Entire Journey
 - Securing systems (straps, bands, locks, or load bars) must remain tensioned throughout the entire transport operation.
 - It is mandatory to ensure there is no loss of tension caused by load settlement.
 - On long-distance routes or transports with multiple stops, periodic stability checks are recommended.
 - Securing must not depend solely on the packaging, but on the vehicle's complete containment system.
- Pre-Inspection of Straps and Locking Systems
 - Before transport begins, the condition and tension of all securing elements must be checked.
 - Damaged, deformed, or worn straps must never be used.
 - Vehicle anchoring points must be properly certified and in good condition.
 - Pre-inspection significantly reduces the risk of load displacement.

Important

One of the most significant risks during material transport is "invisible micro-movement." These are very small displacements, imperceptible to the naked eye, that occur continuously throughout the journey. Although they may not create immediate instability, these movements cause:

- Progressive wear of packaging
- Loss of internal compaction
- Weakening of separators and protective elements
- Increased risk of breakage during later stages of transport or unloading

The absence of visible movement does not guarantee stability. The most critical damage is often caused by the accumulation of undetected micro-movements.



Unloading is the moment when the logistics system stops “actively protecting” the material. For this reason, it requires the same level of control as loading and transport, as it is one of the phases with the highest probability of damage if not carried out in an orderly and progressive manner.

BASIC PRINCIPLES OF SAFE UNLOADING

Safe unloading is based on one fundamental principle: the load must remain stable until the last securing point. Partial or progressive release without control must never be carried out, as any loss of support can generate instability within the load. Throughout the entire operation, the material must maintain continuous support, avoiding sudden changes to its equilibrium condition.

In addition, it is essential that the unloading team works in a coordinated manner. Uncontrolled simultaneous maneuvers increase the risk of unexpected displacement, therefore every action must be synchronized and supervised.

Risk Control During Unloading

During the operation, one of the main risks is the appearance of tilting in the pallet or load assembly during extraction. This must be avoided at all times by ensuring that the load remains perfectly aligned with the vehicle.

It is also necessary to minimize any sudden movement of both the truck and the load during opening operations. Handling must be smooth and controlled, especially when using forklifts, suction cups, or lifting systems, always avoiding point loads that may concentrate stress in a single area.

Temporary unstable supports, such as edges, uneven surfaces, or areas not designed to support loads, must never be used, as they may compromise the integrity of the material.

Unloading Equipment Requirements

The equipment used must be suitable for the weight of the frame, pallet, or complete load assembly. In other words, it must have sufficient load capacity to guarantee safe handling at all times.

Forks must be correctly dimensioned, leveled, and aligned, avoiding imbalances or pressure points. In addition, the equipment must guarantee total stability during maneuvers involving elevated loads, especially during lifting and transport phases.

Another key aspect is the ability to perform smooth, progressive, and fully controlled movements, without shocks or sudden acceleration that could affect the stability of the load.

Objective: maintain load stability throughout the entire transition between the transport vehicle and the storage or receiving area.

Correct unloading procedure

The procedure must follow a controlled and orderly sequence. First, the forks must be inserted fully centered beneath the load support, ensuring uniform weight distribution.

Next, lifting must be progressive and continuous, avoiding any type of impact, vibration, or sudden pulling movement. Once elevated, the load must be extracted from the vehicle in a straight line, without turning during removal.

Afterward, the load assembly must be placed through controlled lowering onto a stable, flat surface prepared to receive the load. Finally, transport to the storage area must always be carried out with the load maintained in a low and stable position.

Key Principle

The unloading process must reproduce stability conditions equivalent to those during transport, avoiding at all times the introduction of new mechanical stresses into the system.

LOADING / UNLOADING OF CRATES FROM CONTAINERS

Handling operations carried out inside the container must be performed with special attention:

- Load capacity: 1,300 kg (2,600 kg for two crates) with center of gravity at 1,750 mm
- Fork length: 2,600 mm
- Note: Verify the equipment lifting clearance height when handling a single crate.

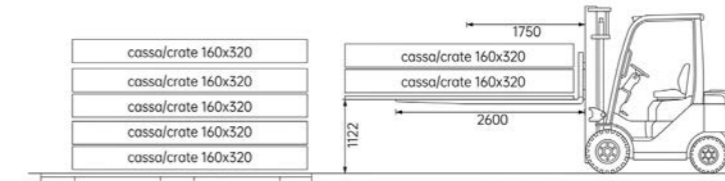

The nature and dimensions of the product always require caution and attention during load handling, in particular:

- Maintain a moderate operating speed.
- Due to the size of the packaging, visibility from the operator’s position may be reduced; therefore, extra caution is required.

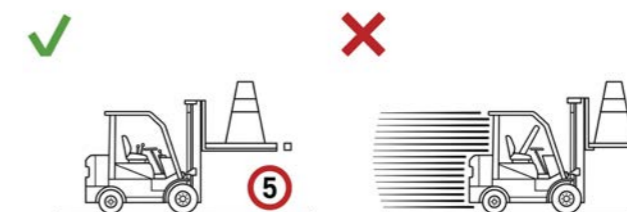

Safety conditions

- The unloading area must be clean, level, and free of obstacles.
- There must be sufficient space for the full maneuvering of the forklift or lifting equipment.
- It is forbidden to handle individual slabs outside the frame or palletized system.
- The load must always remain as a compact and controlled structural unit.

⚠ Avoid mistakes

- Partial or unbalanced extraction of the frame or pallet.
- Sudden movements during the removal of the load from the vehicle.
- Turning movements with the load raised.
- Unloading on uneven, inclined, or unstable surfaces.
- Separation of slabs before the assembly is fully stabilized.

USE OF MACHINERY

In the handling of large-format materials, machinery selection must not be based on operational availability criteria, but on its technical compatibility with the packaging system, the load geometry, and its structural behavior during lifting and movement.

Forklift truck

It is essential to use forklifts with an appropriate load capacity for this type of operation. Special attention must be paid to the sizing of the forks used in the different handling activities, always working under safe conditions and in compliance with current regulations and the "Equipment Use and Maintenance Manual".

As a guideline, and always subject to verification in each specific case, the following fork dimensions are recommended for handling the packaging described above.

For crates containing 120x280 cm products, when handling from the short side of 2,600 mm, 1500 mm forks are recommended.

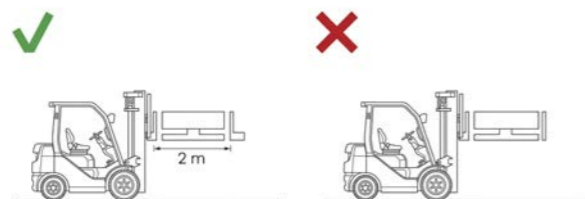

For 160x320 cm slab crates, the forks should always be fully opened to support the largest possible surface area of the crate. From the long side of 2600 mm, forks with a minimum length of 1500 mm are recommended.

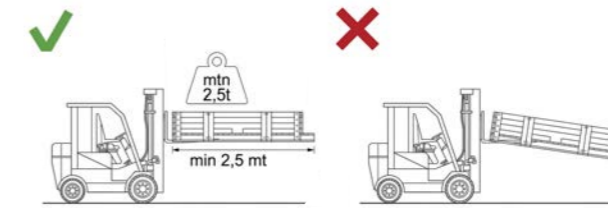

The forklift is the main equipment for handling palletized loads or large-format frames. Its use must always guarantee load stability and avoid any point loads on the material.

Load-appropriate capacity

The forklift must be dimensioned according to the total weight of the frame or pallet, considering not only the nominal capacity of the equipment, but also real working conditions. These include possible load center shift, lifting height during handling, and the dynamic behavior of long loads during movement.

In this type of material, effective machine capacity is reduced when the load has an elongated geometry, as inertia effects increase and sensitivity to acceleration or braking becomes higher.

Fork length

Fork length is one of the most critical factors in handling safety. Forks must ensure full, continuous, and uniform support of the frame or pallet, avoiding any concentrated loads at intermediate points.

For formats such as 120x280, a minimum fork length of 2600 mm is recommended to ensure full frame support and prevent cantilever bending during lifting or movement. For larger formats such as 160x320, a minimum length of 2600 mm is also recommended, being essential to avoid leverage effects and ensure longitudinal stability of the assembly.

As a general technical rule, if the forks do not cover at least 80–90% of the support base, there is a significant structural risk during handling.

Risks associated with insufficient fork length

Using inadequate fork lengths may cause frame bending during lifting, load concentration in central areas, lateral instability during maneuvers, and an increased risk of non-visible micro-cracks in the material. These effects may not be immediate but can compromise product integrity throughout the entire logistics process.

Pallet jack

The pallet jack must be considered a limited-use tool within the context of large-format handling, and only applicable under very specific safety conditions.

Its use is restricted to small or compact loads, short-distance movements, and completely flat and stable surfaces. In addition, it is only suitable when the product has a fully rigid support ensuring load stability during movement.

Risk of incorrect use

Incorrect use generates a high risk due to lack of center of gravity control, insufficient continuous support, and increased vibrations transmitted directly to the material. It may also cause torsion in the packaging and loss of load stability during movement.

Key principle

The pallet jack must not be considered a lifting system for large formats, but only a highly limited auxiliary movement tool under strictly controlled conditions.

Conclusion

In large-format material handling, the choice between forklift and pallet jack directly determines the level of risk to which the material is exposed, making it a critical factor in preventing structural damage and non-visible failures.

MANUAL HANDLING

In many technical manuals, manual handling appears only superficially or is even omitted, despite being one of the highest-risk phases in large-format materials.

Minimum number of operators

Safe manual handling requires a minimum number of operators depending on size, weight, and fragility. As a general rule:

Two operators are only suitable for very light and fully controlled operations where structural risk is minimal and the material remains stably supported throughout the process. Three operators are the recommended standard for medium-sized pieces, allowing balanced effort distribution and better stability control.

Four operators are required for large-format or highly fragile pieces, where longitudinal axis control and bending prevention are critical.

The fundamental principle is that the load must never be concentrated at a single control point or depend on a single operator.

Mandatory use of suction cups

The use of suction cups is mandatory in the manual handling of large-format materials. These systems are the main safe gripping method, allowing load distribution across the surface of the slab.

Suction cups must be specifically designed for large formats, with adequate load capacity and balanced distribution to ensure stability during lifting and movement. Their main function is to reduce direct edge loading, avoid manual contact in critical areas, and ensure uniform load control.

From a technical standpoint, suction cups are not a convenience tool but a structural system that enables safe handling without compromising integrity.

Prohibition of unsupported lifting

It is strictly forbidden to lift slabs without an appropriate support system. Materials must never be handled by gripping edges or corners alone, nor lifted without suction cups or equivalent systems.

It is also not permitted to lift slabs horizontally without proper bending control or to perform movements involving loss of structural support.

These practices create a direct risk of micro-cracks due to instantaneous bending, delayed fractures, and panel torsion during lifting.

Structural safety principle

Throughout manual handling, the slab must maintain continuous or semi-continuous support ensuring structural control. Under no circumstances should the material be left suspended without controlled support or proper load distribution.

Common critical mistakes

Common mistakes include lifting slabs between two operators without proper coordination, insufficient use of suction cups, direct gripping of edges, rotating slabs in the air without structural support, and lack of synchronization between operators.



MOVEMENT OF SLABS

In construction or warehouse environments, large-format material enters its most sensitive logistical phase. At this point, the slab is no longer protected by transport packaging or containment systems and depends entirely on operator control.

Movement must therefore be considered a critical phase where any loss of control is transmitted directly to the material without structural damping.

Requires support systems

Slab movement must always be carried out using systems specifically designed to maintain structural integrity, such as large-format transport trolleys, mobile frames, industrial suction systems, or stable support trestles.

These systems are not optional, as they form the basis of structural control during movement. Slabs must never be moved in a “free” state without continuous support.

Never drag

It is strictly forbidden to drag slabs over any surface, including construction floors, uneven ground, pallets, temporary structures, or work tables without proper rolling systems.

Dragging creates direct risks such as friction-induced micro-cracks, edge breakage due to continuous impact, panel torsion due to uneven support, and invisible wear that weakens the slab before installation.

Safe movement conditions

Safe movement requires level surfaces, continuous support on rigid frames, slow and controlled movements without vibration, and coordinated operators when necessary.

Suction cups may be required to ensure directional control and stability, especially in large formats or directional changes.

Critical on-site errors

Common errors include moving slabs without support systems, improvising transport means with non-designed pallets or boards, turning in tight spaces without structural control, handling slabs vertically without proper fixing, and placing slabs directly on the floor without protection.

USE OF SUCTION CUPS

Suction cups and frames are not auxiliary accessories but essential structural elements of the handling system.

Suction cups for gripping

Suction cups are the main contact point between operator and slab. Their function is to create a secure grip, distribute load without concentrating stress on edges, allow movement control without direct manual contact, and reduce torsion risk during lifting.

They must be symmetrically positioned, applied on clean surfaces, vacuum-verified before lifting, and distributed according to slab size.

Incorrect use (insufficient quantity, asymmetry, lack of vacuum check, or poor coordination) creates direct torsion and instability risks.



CORRECT MOVEMENTS

Movement technique is as important as equipment.

Movement should preferably be vertical or slightly inclined.

Torsion is one of the most critical risks in large-format materials.

Lifting must be uniform and synchronized across all support points, applying simultaneous force, maintaining a stable center of gravity, and ensuring constant controlled speed.

WHAT NOT TO DO

It is forbidden to bend the material, support it on corners or edges, or drag it over any surface. Bending generates internal micro-cracks even without visible breakage.

Point support creates critical stress concentrations that may cause immediate or delayed failure.

Dragging generates wear, accumulated vibration, and progressive loss of structural integrity.



KEY TOOLS

In large-format handling, tools are not optional elements or simple supporting accessories. They are an essential part of the structural system for safe handling. The correct selection of equipment directly determines material integrity throughout all phases of the logistics process, from initial handling to storage or installation.

Double/triple suction cups

Suction cups are the main gripping system during the handling of large-format slabs. Their function is to ensure safe control of the material, avoiding direct contact with edges and distributing the load across multiple surface points.

Double suction cups are used for medium-sized slabs or controlled handling operations where structural balance is relatively stable. Triple suction cup systems or multi-point systems are mandatory for large-format or longer slabs, as they allow a wider load distribution and significantly reduce the risk of torsion during lifting.

Positioning must always be symmetrical and balanced, ensuring that all gripping points work in coordination. Incorrect distribution creates center-of-gravity imbalance and increases the risk of deformation during handling.

From a technical standpoint, the larger the slab, the greater the number of gripping points required to maintain structural stability of the system.

Aluminum Frames

Aluminum frames are the main structural support during transport and storage of large-format materials. Their function is not only to contain the slabs, but to guarantee the overall stability of the system throughout all logistics phases.

These systems allow slabs to remain in a stable vertical position, reducing flexion and avoiding unnecessary stress on the material. They also allow multiple slabs to be grouped into a single rigid unit, facilitating mechanical handling and reducing variability in individual behavior between elements.

From a structural perspective, aluminum frames are characterized by their lightweight yet highly resistant construction, compatibility with forklifts, integrated fixing points for straps or locking systems, and built-in separators that protect slab edges.

Correct use of the frame ensures that the system behaves as a single coherent structure, preventing independent movement of slabs during transport.

Transport carts

Transport carts are designed for the internal movement of large-format materials within warehouses or construction sites, as well as for short-distance transfers between work areas. Their main function is to minimize direct manual handling while keeping the slab within a controlled support system.

Proper use of this equipment requires completely level surfaces, centered load positioning, slow, progressive, and fully controlled movements, and compatibility with frames or rigid structures that ensure system stability.

Using carts on uneven surfaces significantly increases vibration transmission to the material, which can lead to micro-cracks or loss of structural stability, even when no immediate visible damage occurs.

Crane with suction system

Crane systems equipped with suction devices are intended for the handling of large-format slabs at height, especially during installation phases such as façades, cladding, or vertical elements. Their main function is to enable safe vertical movement of the material without direct manual contact.

These systems incorporate high-safety vacuum technology that ensures stable slab grip throughout the entire operation. They also allow rotation and orientation control of the material, as well as fine adjustments during final positioning.

From a technical perspective, crane suction systems completely eliminate manual handling in the most critical phases of the process, significantly reducing the risk of human error and damage due to incorrect handling.



Double/Triple Suction Cups



Aluminum Frames



Transport Carts

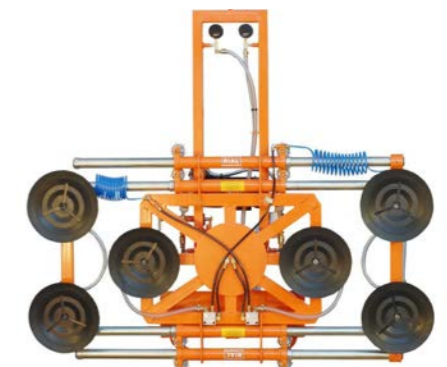

Crane with Suction System



STORAGE POSITION

In large-format storage, positioning is not a flexible or arbitrary variable, but a strictly defined condition determined by packaging resistance, slab format, and the structural limits of the palletizing or framing system.

Respecting stacking limits

Each packaging system has a technically defined maximum stacking limit. This limit depends on the structural resistance of the packaging (wood, frame, or other systems), the total unit weight, the vertical load distribution, and the overall stability of the assembly.

The fundamental principle is that stacking is not determined by available space, but by the structural capacity of the lower unit.

Exceeding these limits may cause deformation of the lower packaging, direct load transfer to the slab, loss of vertical alignment, and the development of accumulated internal stresses. Damage does not necessarily appear immediately, but may occur during prolonged storage periods.

Only intact packaging

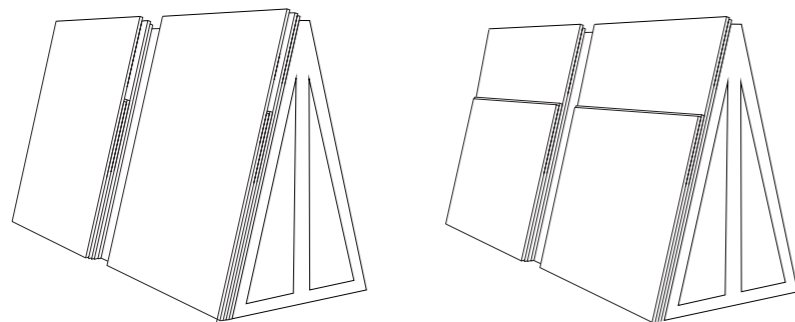

"Do not place large boards on smaller boards:"

✗ INCORRECT

✓ CORRECT

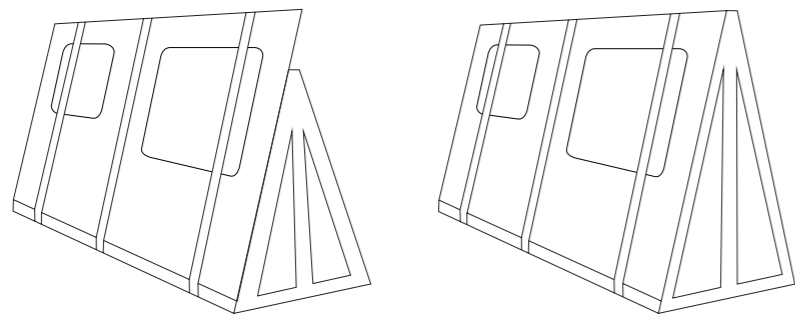

"Likewise, ensure that the trestle or base supporting the boards is larger than the surface of the slab:"

✗ INCORRECT

✓ CORRECT

SEPARATION BETWEEN SLABS

In large-format handling, separation between slabs is not an accessory element but a critical component of the structural protection system, essential to prevent contact damage and vibration transmission.

Avoid direct contact

Under no circumstances should direct contact between slabs occur. Ceramic-to-ceramic contact generates micro-impacts due to vibration during transport and storage, surface abrasion, edge breakage due to accumulated pressure, and stress transmission between elements.

Two slabs in contact do not behave as independent units but as a coupled system that transfers vibration and load between surfaces.

Use of separators

Separators play an essential role in cushioning and isolating slabs. Common materials include high-density technical foam, multilayer technical cardboard, plastic or rubber profiles, and specific edge protection elements.

Their technical function is to absorb micro-impacts, prevent direct pressure points, maintain a constant distance between slabs, and protect both edges and finished surfaces.

The separator not only protects but also structurally decouples slabs within the packaging system.

MAXIMUM RECOMMENDED STORAGE TIME

Prolonged uncontrolled storage is a risk factor frequently underestimated in large-format technical manuals. Even when the product is correctly packaged, time introduces progressive degradation factors that may affect the entire system.

Avoid prolonged storage

Material should not remain stored for unnecessarily long periods without inspection. Time can affect packaging stability, separator rigidity, appearance of micro-deformations due to stacking, and environmental conditions such as humidity, temperature, or dust accumulation.

The fundamental principle is that safe storage is not indefinite, but a time-controlled condition.

Mandatory periodic inspection

Periodic inspections of stored material are essential, verifying packaging integrity, stack stability, absence of visible deformation, and proper condition of separators and protective elements.

Many damages do not occur during transport but during prolonged storage without intermediate control.

Unmonitored storage may cause loss of packaging rigidity, base settlement in stacked loads, development of residual stresses, and progressive degradation of protective elements.

Conclusion

Storage must be understood as a dynamic phase in which material stability depends both on correct initial placement and on periodic control of its condition over time.



HEADQUARTERS
CTRA. CASTELLÓN, 117
ALCORA 12110 (CASTELLÓN)

LOADING ADDRESS
CENTRO LOGÍSTICO 11. GRUPO PAMESA
CTRA. CASTELLÓN - ALCORA
PZA. POLÍGONO 4, 4 PG.12
SAN JOAN DE MORÓ 12130
(CASTELLÓN)

+34 964777700 | info@ascale.es

ASCALE
Nature inspiring innovation